



Arcobaleno

H A N D B A G

Andrà Tutto Bene



ITALIAN DESIGNER

I AM VALERIA ZINGARETTI AND I BORN IN JESI (ITALY) IN 1988.
I AM AN ITALIAN DESIGNER AND MULTIFACETED ARTIST.

I FOCUS MY ATTENTION ON MATERIAL RESEARCH, LEATHER
COMPOSITIONS, DESIGN AND CRAFTMANSHIP.

I PRESENTED THE ARCOBALENO HANDBAG TO THE DAB 2021
TO EXPRESS THAT FASHION AND DESIGN CAN BE A GREAT
SYMBOL OF HUMAN LIFE AND OUR SOCIETY.

MY DESIGN FOLLOWS THE ETHICAL PHILOSOPHY OF ECODSIGN
AND SUSTAINABILITY TO SAVE RESOURCES, RESPECTING THE
ENVIRONMENT.



ARCOBALENO

THE ARCOBALENO HANDBAG IS INSPIRED BY THE RAINBOW DRAWINGS MADE BY ITALIANS DURING THE COVID-19 PANDEMIC.

IN 2020, LOTS OF ITALIAN PEOPLE DREW A RAINBOW ON THEIR BALCONIES, TO SYMBOLIZE THE LIFE AND THE JOY AFTER THE RAIN.

THE DESIGN IS MINIMAL AND COLORFUL AS ALL THE IMPORTANT THINGS IN HUMAN LIFE.

ARCOBALENO IS A FASHION ACCESSORY MADE WITH RECYCLED LEATHERS TO MAKE IT A SUSTAINABLE AND ECOFRIENDLY PRODUCT.



CONCEPT

“ARCOBALENO” IS THE ITALIAN WORD FOR “RAINBOW”.

THE ARCOBALENO HANDBAG EXPRESSES THE CONCEPT OF NATURE, FREEDOM AND HUMAN LIFE.

FOR THAT REASON, DURING THE COVID-19 PANDEMIC LOTS OF PEOPLE IN ITALY DREW ON THEIR BALCONIES THE COLORFUL RAINBOW TO EXPRESS THE HOPE FOR THE FUTURE.

THE CONCEPT IS AN OPTIMISTIC VISION OF THE FUTURE IN A FASHION ACCESSORY.

“ANDRA’ TUTTO BENE” MEANS “EVERYTHING IS GONNA BE ALL RIGHT”

Health

Nature

Community

Life

Hope

Freedom

Future

A technical diagram showing the geometric construction of a bag. It features a central vertical axis and a horizontal axis. The bag's body is a semi-circle at the bottom, with a handle at the top. The handle is formed by seven parallel lines that curve inward at the top. The entire design is overlaid with a grid of light blue circles and lines, illustrating the geometric construction. A brown rectangular box is positioned in the upper right corner, containing the title 'GEOMETRIC SHAPE'.

GEOMETRIC SHAPE

THE DESIGN IS GEOMETRICAL, MINIMAL AND SIMPLE. THE CIRCLES AND LINES CREATE THE SYMMETRICAL SHAPE OF THE BAG.

THE HANDLES ARE MADE BY SEVEN LEATHER LINES PUT TOGETHER, DEVELOPING SOFT CURVES ON A SEMI CIRCLE BAG.

TECHNICAL DRAWING

THE DIMENSIONS ARE: 28x24x14 CM.

THE BAG IS LIGHT AND EASY TO USE.

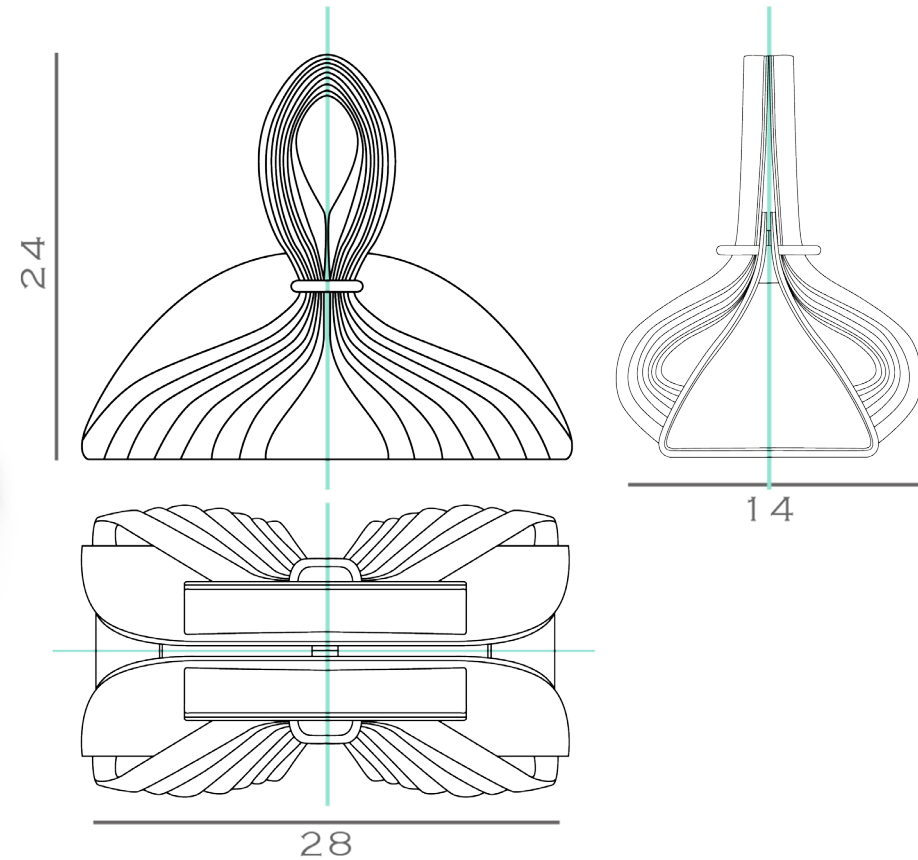



COLOR & TRIM

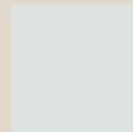

WHITE PATENT LEATHER
NATURAL LEATHERS



RED
ORANGE
YELLOW
GREEN
LIGHT BLUE
BLUE
PURPLE

THE MATERIALS USED ARE RECYCLED ITALIAN LEATHERS TO REPRESENT THE COLORS OF THE RAINBOW IN A FASHION ACCESSORY.

THE RAINBOW IS MADE BY SOFT LEATHERS (NAPPA) AND GOAT LEATHERS IN DIFFERENT COLORS. THESE KIND OF LEATHERS ARE THIN, PLIABLE AND DURABLE.

THE PROPERTIES OF THE LEATHERS DEFINE THE SHAPE OF THE HANDLE, ALLOWING THE STRIPS TO CONNECT WITH THE GOLD METAL ACCESSORY. THE EXTERNAL PART OF THE BAG IS MADE OF RECYCLED LEATHER IN WHITE PATENT LEATHER TO ENHANCE THE COLORS OF THE HANDLE AND HAVE REFLECTIONS ON THE SURFACE. THE LATERAL PART OF THE BAG IS MADE BY SOFT LEATHER IN NATURAL COLOR TO MAKE THE BAG LIGHT AND EASY TO OPEN. THE INSIDE ONE IS MADE BY NATURAL LEATHERS IN LIGHT BROWN AND NATURAL COLORS.



PROTOTYPE



THE BAG IS ENTIRELY DESIGNED, SEWN AND MADE BY VALERIA ZINGARETTI.

FINAL VIEW







ARCOBALENO HANDBAG



THANK YOU FOR ATTENTION



Andrà Tutto Bene